

# CARGO 150 AS – CHEST TYPE -



ATP















## Chest type isothermal container for the transport of chilled and frozen products under controlled temperature conditions.

- Equipped with a practical **top hinged lid**, it allows to take full advantage of the load capacity.
- Ideal for transporting **bulk produce**.
- Capacity: 148 litres.
- Easy to manoeuvre, thanks to the dedicated zinc coated trolley.
- It assures proper heat retention, limiting the risk of bacterial proliferation whilst preserving food quality and organoleptic characteristics.
- The isothermal characteristics comply with current regulations (EC Reg. 852/2004 –HACCP-) and with applicable technical standards (EN12571 and Accord AFNOR AC D40-007).
- Manufactured using the rotational moulding technology, allowing production of very sturdy objects without sharp edges, joints or welds, whilst assuring highly efficient temperature retention.
- Designed to be long lasting: performance remains basically unaltered when reused.
- **Fully recyclable** at the end of the operating life.

### MANUFACTURING MATERIALS

<b>Polyethylene</b>	inner and outer walls of the container and of the lid; food contact safe	<b>Polyurethane</b>	insulating material between the walls of the container and of the lid; free of CFC and HCFC
<b>Silicone rubber</b>	seal	<b>Fiberglass reinforced polyamide</b>	hinges, clasps
<b>Stainless steel</b>	handle on lid, lid retaining chain	<b>POM acetal resin</b>	handle cover on lid

**TECHNICAL CHARACTERISTICS**

	<p>Hot (red), chilled (pink), extra-chilled (sand) frozen (blue) and extra frozen (green) eutectic plates to extend the temperature retention time of the products (on request).</p>		<p>Chilled (white) and frozen (white with red tap) eutectic plates to extend the temperature retention time of the products (on request).</p>
	<p>Model for dry ice transport available.</p>		<p>Easily removable door seal.</p>
	<p>Integrated stainless steel handles.</p>		<p>Equipped with hinges made of shockproof material, featuring high resistance to stresses.</p>
	<p>Melform hook closure in shockproof material.</p>		<p>Featuring an adjustable venting valve.</p>
	<p>Zinc coated trolley:</p> <ul style="list-style-type: none"> <li>• capacity 200 Kg;</li> <li>• 4 non marking rubber castors with PP centre;</li> <li>• dia. castors: 125 mm;</li> <li>• 4 swivel casters, 2 of which with brake.</li> </ul>		<p>Mono-block structure, no sharp edges, joints and welds.</p>
	<p>Insulated with CFC and HCFC-free polyurethane foam.</p>		<p>Available (on request) USB data logger to record temperature data during transport.</p>
<p><b>°C</b></p>	<p>Container (insulated case) guaranteed for use:</p> <ul style="list-style-type: none"> <li>• <b>from -30° to +100°C.</b></li> </ul>	<p><b>K</b></p>	<p>Overall heat transmission coefficient: <b>K=0.42 W/m2K</b></p>

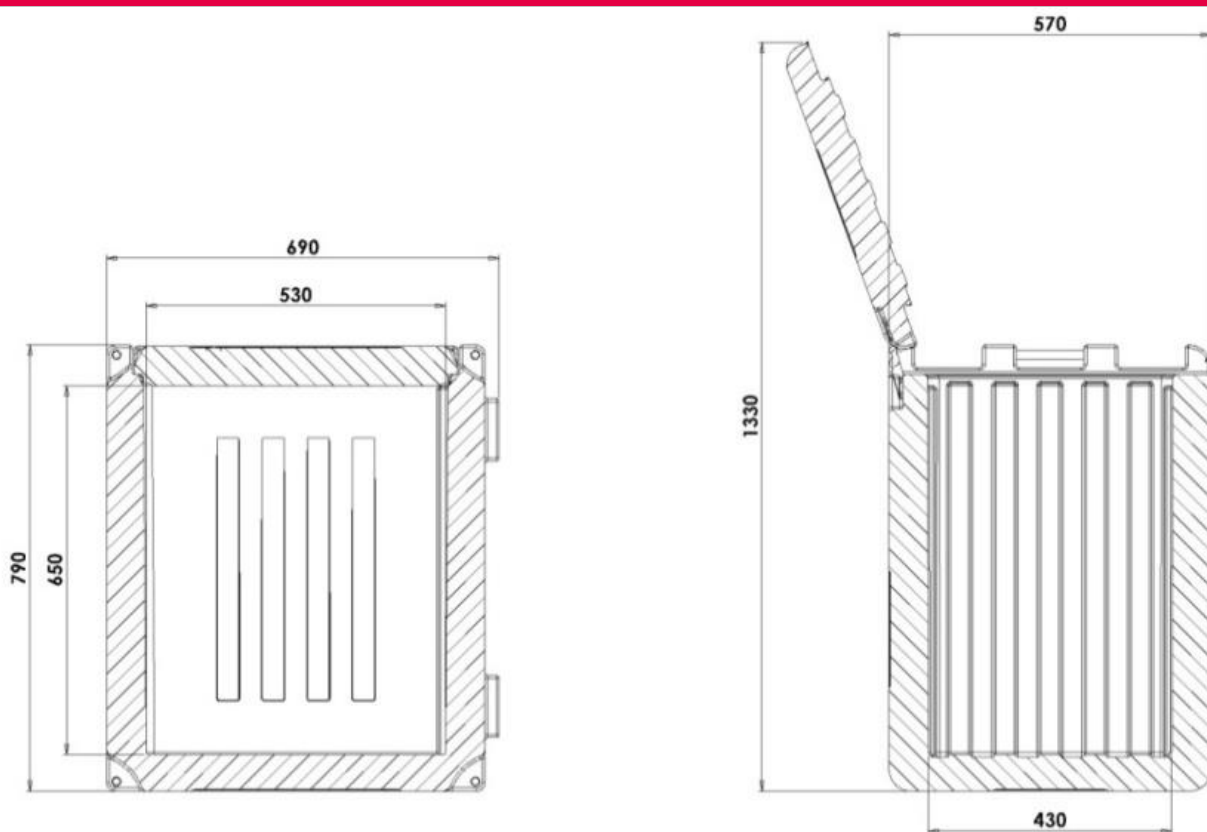

Model	Code	Colour	External dim. (mm)	Internal dim. (mm)	Capacity (liters)	Weight (Kg)
Cargo 150 AS <b>without runners for eutectic plate</b>	A1500011	grey/blue melange	690x570xh790	530x430xh650	148	25
Cargo 150 AS <b>with runners for eutectic plate</b>	A1509059	grey/blue melange	690x570xh790	530x430xh650	148	25
Cargo 150 AS <b>dry ice transport</b>	A1509044	grey/blue melange	690x570xh790	530x430xh650	148	26.5
Hot eutectic plate <b>GN 1/1</b>	PEGS0003	red	530x325xh30			3
Chilled eutectic plate <b>GN 1/1</b>	PEGS0001	pink	530x325xh30			4
Extrachilled eutectic plate <b>GN 1/1</b>	PEGS9001	sand	530x325xh30			4
Frozen eutectic plate <b>GN 1/1</b>	PEGS0002	blue	530x325xh30			4
Extra frozen eutectic plate <b>GN 1/1</b>	PEGS9008	green	530x325xh30			4
<b>Chilled</b> eutectic plate	AGA004	white	210x375xh20			1,5
<b>Frozen</b> eutectic plate	AGB004	white with red tap	210x375xh20			1,5
Trolley <b>zinc coated</b>	AIB002		670x575xh235			11
USB <b>Data logger</b>	AFG007		80x33xh14			

## SPARE PARTS

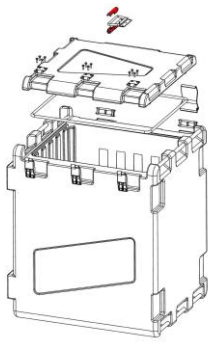
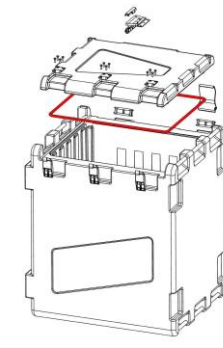
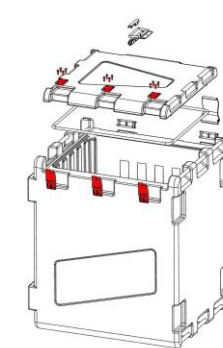
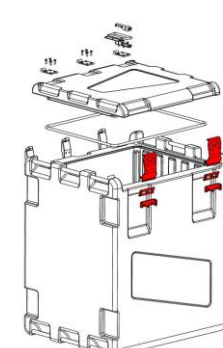
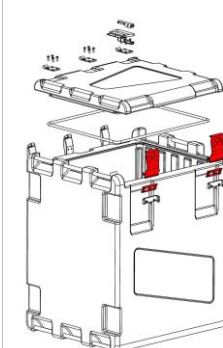
				
<b>RRI019</b>	<b>RRI027</b>	<b>RRI113</b>	<b>RRI112</b>	<b>RRI004</b>
Kit of handle cover	Kit of gaskets	Kit of hinges	Kit of plastic catches	Kit of blades for plastic catches
2 pcs for packing	5 pcs for packing	2 pcs for packing	4 pcs for packing	2 pcs for packing