

# DrIcy 150



## Insulated chest container for Dry Ice transport and delivery

- Comfortable top opening, useful for optimizing the load capacity.
- Containment capacity: 120 kg of dry ice in 3 mm pellets.
- Base with wheels or pallets.
- Reduced height from the ground to facilitate load and collection.
- Perfectly stackable, thanks to the special housings on the lid.
- The small dimensions allow transport on traditional small and medium-sized vehicles.
- Produced with rotational molding technology: container and monobloc door (without sharp edges, joints and welds).
- Fully recyclable at the end of the operating life.
- Easily washable.
- DrIcy containers are suitable for the containment of dry ice at the temperature of -78.5 C. Each plastic material is subject to embrittlement when subjected to extremely low temperatures, therefore it is recommended to avoid the use of metal objects for the removal of dry ice residue possibly remaining on the bottom of the container.

### MANUFACTURING MATERIALS

<b>Polyethylene</b>	inner and outer walls of the container and the lid; suitable for food contact.	<b>Polyurethane</b>	insulating material between the walls of the container and the lid; free of CFC and HCFC.
<b>Silicone</b>	gasket.	<b>Stainless steel</b>	closing hooks, gas springs protection casing.
<b>Galvanized steel</b>	hinge rods, reinforced frame, feet.		

## TECHNICAL CHARACTERISTICS

	<p>Double adjustable stainless steel closure with eyelet for seal.</p>		<p>Flat bottom with central drain holes.</p>
	<p>Easily replaceable lid sealing gasket.</p>		<p>Hole with drainage cap positioned on the bottom of the container.</p>
	<p>Ergonomic handles inserted on the body to facilitate safe handling</p>		<p>Dedicated housings for stacking containers.</p>
	<p>Reinforcement frame in galvanized steel.</p>		<p>Version with 4 wheels (2 swivel and 2 swivel with brake). Version with 4 galvanized steel feet mounted on integrated support plates.</p>
	<p>Monobloc structure, without sharp edges, joints and welds. Insulation with CFC-free and CFFC-free polyurethane foam.</p>		<p>Label holder for the identification of the content or destination.</p>
<p><b>K</b></p>	<p>Overall heat transmission coefficient: <b>K=0,29 W/m²K.</b></p>		

## TECHNICAL SPECIFICATIONS

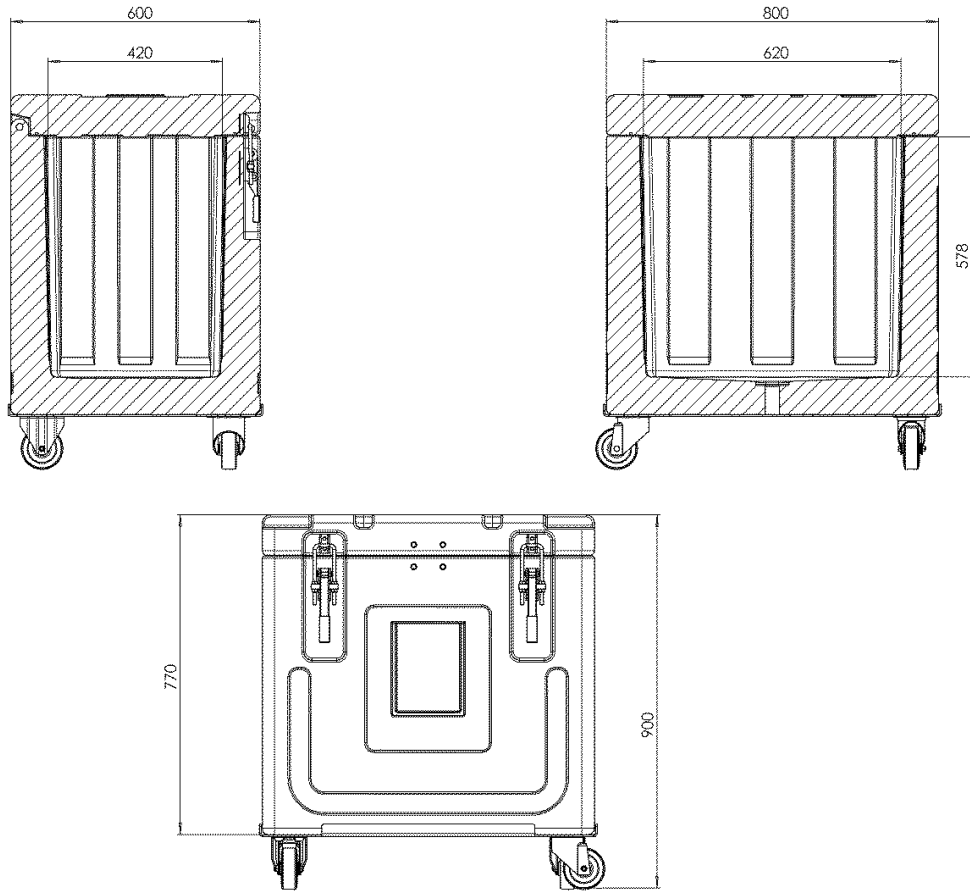

Model	Code	Colour	External dim. (mm)	Internal dim. (mm)	Capacity (liters)	Weight (kg)
DrIcy 150 with castors	0150S001	grey blue melange	800X600Xh900	620x420xh578	150	49
DrIcy 150 with pallet	0150S002	grey blue melange	800X600Xh900	620x420xh578	150	49